

# Manual Grating-Based Fiber Optic Tunable Filter – 0.15nm Bandwidth



(patent pending)

DATASHEET

BUY NOW



Agiltron's Manual Grating-Based Fiber Optic Tunable Filter provides a simple way to adjust the center wavelength of narrow band over wide band. Wavelength tuning is achieved by rotating a grating using a micrometer.

Based on a proprietary optics, Agiltron offers extremely low insertion loss, high stability, polarization independent operation, and high off-band suppression. It is tunable continuously over a wide spectral range. The device presents a most cost-effective solution for OEM applications from fiber optic networks to fiber sensing interrogation.

## Features

- Extremely low insertion loss
- Wide Tune Range
- High off-band suppression
- Uniform bandwidth
- High tuning resolution
- Compact and cost-effective

## Applications

- DWDM networks
- Fiber Sensing
- ASE control
- Tunable Fiber Lasers

## Specifications

Parameter	Min	Typical	Max	Unit	
Wavelength Tuning Range	1060 ± 15	1500 ± 20	2000 ± 20	nm	
Tuning Resolution	-	0.02	-	nm	
Insertion Loss [1]	B-Grade	1.5	2.1	3.5	dB
	A-Grade	1.1	1.6	2	dB
Bandwidth @-3dB	0.15	-	0.20	nm	
Bandwidth @-20dB	-	0.5	-	nm	
Polarization Dependent Loss	-	0.25	-	dB	
Extinction Ratio (PM fiber only)	-	20	-	dB	
Off-Band Suppression	-	45	-	dB	
Polarization Mode Dispersion	-	-	0.5	ps	
Return Loss	40	-	-	dB	
Optical Power Handling (CW)	-	-	500	mW	
Operating Temperature	0	20	60	°C	
Storage Temperature	-10	-	70	°C	
Dimension	88 x 32 x 24			mm	

### Notes:

[1]. Measured using a broadband light source with the integration of the transmission peak. If the laser source does not match the filter profile, an extra loss can occur. A special filter can be made to match the application. The smaller the fiber core, the higher the loss. Excluding connector loss. The connector adds 0.25dB each

Legal notices: All product information is believed to be accurate and is subject to change without notice. Information contained herein shall legally bind Agiltron only if it is specifically incorporated into the terms and conditions of a sales agreement. Some specific combinations of options may not be available. The user assumes all risks and liability whatsoever in connection with the use of a product or its application. Agiltron, The Power to Transform and Agiltron logo are trademarks of Photonwares Corporation. © 2009, 2012 IPG Photonics Corporation. All rights reserved.

Rev 04/17/24

© Photonwares Corporation

+1 781-935-1200

[sales@photonwares.com](mailto:sales@photonwares.com)

[www.agiltron.com](http://www.agiltron.com)

Information contained herein is deemed to be reliable and accurate as of the issue date. Photonwares reserves the right to change the design or specifications at any time without notice. Agiltron is a registered trademark of Photonwares Corporation in the U.S. and other countries.

# Manual Grating-Based Fiber Optic Tunable Filter – 0.15nm Bandwidth



(patent pending)

## DATASHEET

### Mechanical Dimension (mm)

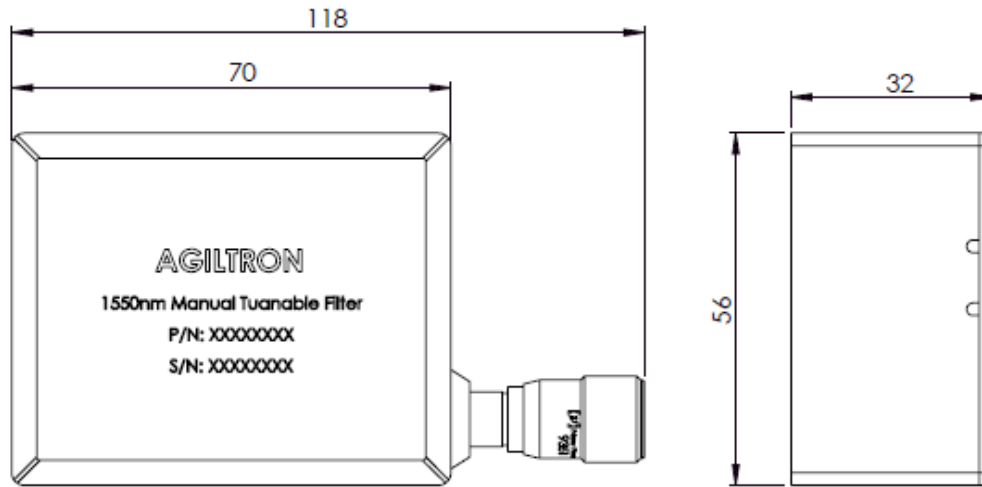

\*Product dimensions may change without notice. This is sometimes required for non-standard specifications.

### Spectrum

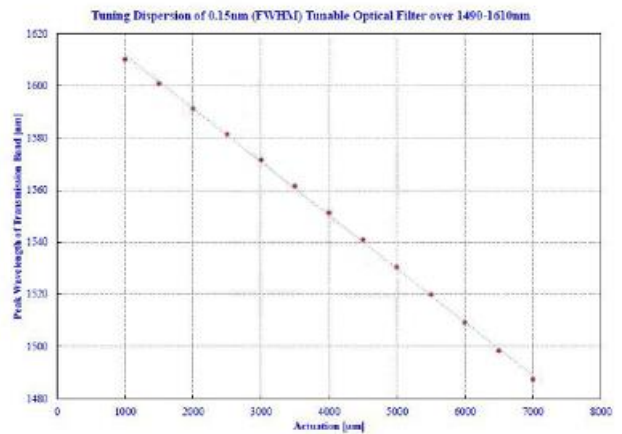
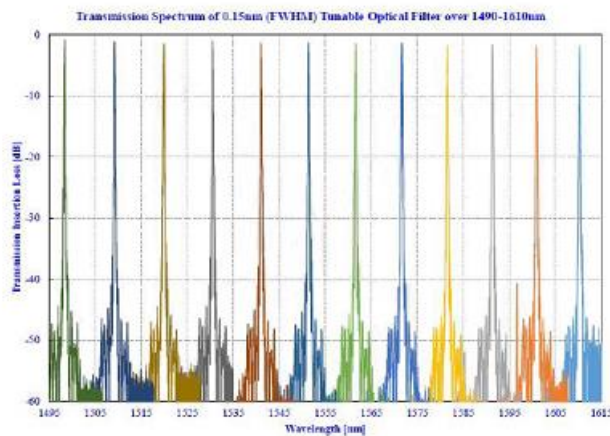

# Manual Grating-Based Fiber Optic Tunable Filter – 0.15nm Bandwidth



(patent pending)

## DATASHEET

### Bandwidth Definition

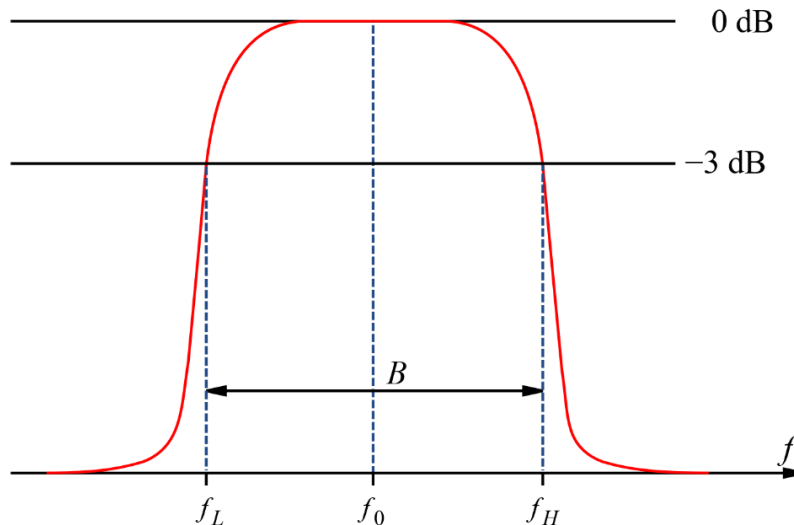

### Ordering Information

Prefix	Wavelength	Power	Type	Fiber Type	Fiber Cover	Fiber Length	Connector
FOTF-	1060nm = 1 1310nm = 3 1550nm = 5 1600nm = 6 2000nm = 2	Regular = 1 5W = 5 Special = 0	B-grade* = 1 A-grade** = 2	SMF-28 = 1 PM1550 = 5	900um tube = 3 Special = 0	0.25m = 1 0.5m = 2 1.0 m = 3 Special = 0	None = 1 FC/PC = 2 FC/APC = 3 SC/PC = 4 SC/APC = 5 ST/PC = 6 LC/PC = 7 Special = 0

\* B-grade <3.5dB

\*\* A-grade <2.0dB

NRE charge is required for red line.

### How to test the insertion loss of a tunable optical filter

The filter only works in a specific range. Beyond this range, extra peaks may show. These peaks can be blocked with special order. Please follow these instructions to do an optical insertion loss test:

1. Connect a broadband fiber-coupled laser source to OSA, sweep one time over the specified range of the tunable filter, and then fix the curve in Trace A as a reference.
2. Connect the broadband laser source to the fiberoptic tunable filter fiber as input, then connect the other fiber port of the tunable filter as the output to the OSA.
3. Set OSA Trace B as 'write,' Trace C as 'Calculate: B-A.' Auto sweep Trace C from the specific range. Tune the micrometer to shift the peak at a different wavelength. Use 'Peak search' to record IL at a different wavelength."